

TURNING A BALANCE STAFF

TRAINING UNIT
NUMBER 3A



TURNING BALANCE STAFFS



TURNING A BALANCE STAFF

There are many priceless heirlooms handed down from generation to generation and now in the possession of representative people who place high values upon these watches. The largest percentage of these are not in running order and the owners are willing to pay well for the thrill of seeing these watches again tick off the hours, minutes and seconds. Material for these watches can not be purchased.

A watch that had a balance staff replaced by the use of imitation material or poor workmanship, which caused the hole in the balance arms to be enlarged, so that a genuine staff can not be used, must have a balance staff turned to fit the new dimensions.

Herein are the real reasons for the necessity for staff making, and the watchmaker who can turn a balance staff with a sufficient degree of accuracy so that the watch is restored to its original running condition, will establish himself as high grade watchmaker.





BULOVA SCHOOL *of* WATCHMAKING

TRAINING UNIT NUMBER 3A

Subject:

Balance Staff Turning.

Objective:

To develop skill and proper methods in turning balance staffs.

Practical work — 60 hours.

Related theory — 12 hours.

New Tools Required:

- | | |
|-------------------------|-------------------|
| 1 Alcohol lamp | 4 Bellmetal slip |
| 2 Millimeter micrometer | 5 Iron metal slip |
| 3 Polishing Block | 6 Pin vise |
| | 7 Cement brasses |

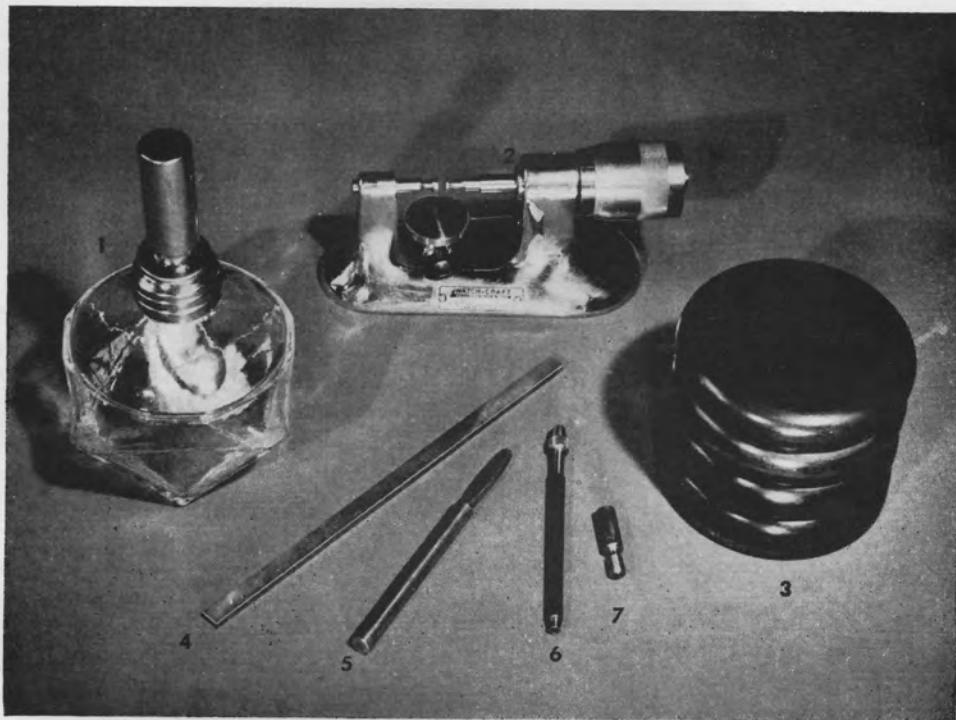

Training Unit Number 3a

Select a piece of steel wire, with a diameter slightly larger than the largest diameter of the sample staff. In this case, stock of three millimeters thickness will be used. Make a blank one tenth of a millimeter longer than the sample. (See Fig. 1) Harden and temper this blank to a full blue color. (See hardening and tempering)

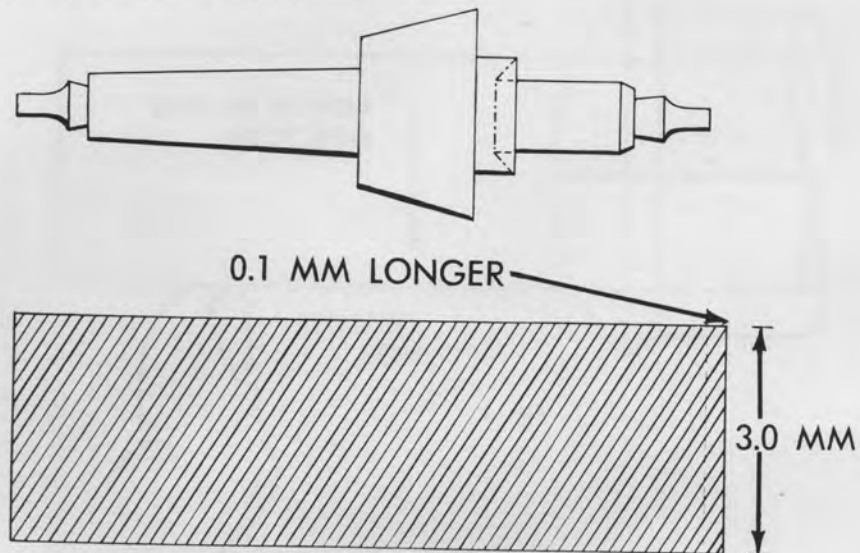

Fig. 1

Select a number 30 chuck which will fit the blank correctly. Chuck the blank in the lathe to extend out from the chuck far enough so that the hub of the staff can be turned. (See Fig. 2)

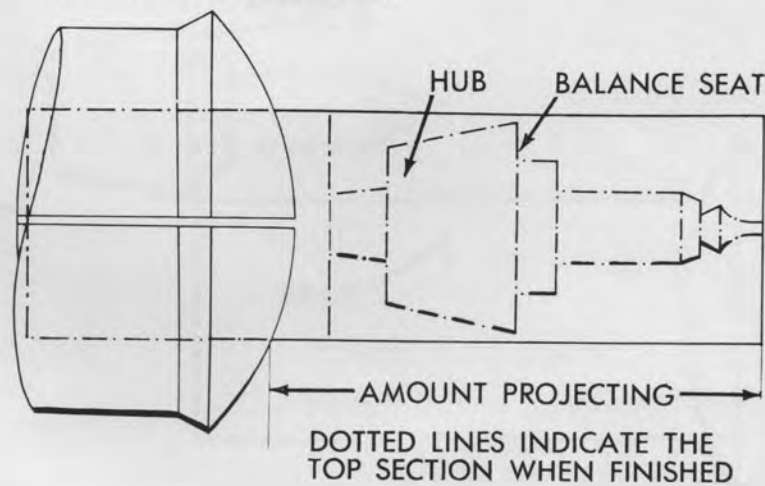

Fig. 2



Training Unit Number 3a

Tighten the chuck just enough to prevent the staff from falling out while the lathe is rotating. With the thumb nail, true the staff by applying a little upward pressure on the underside of the blank while the lathe is in motion. (See Fig. 3) Tighten chuck and with a loupe examine the blank for trueness. This will insure that when the graver is presented to the blank, that very little turning will be required to true it.

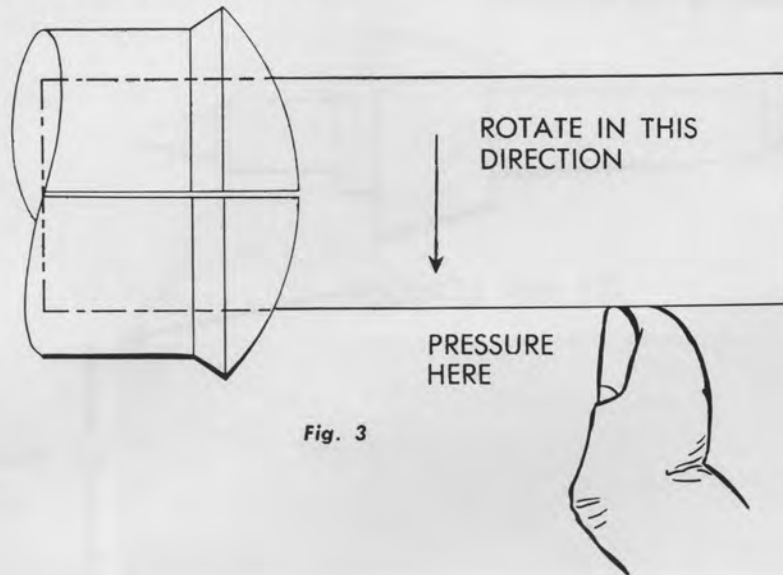

Fig. 3

Clamp the roller shoulder of the sample staff in a pin vise. Place the sample staff parallel with the blank, so that the balance seat can be marked with a graver. (See Fig. 4) From this mark proceed turning the balance shoulder.

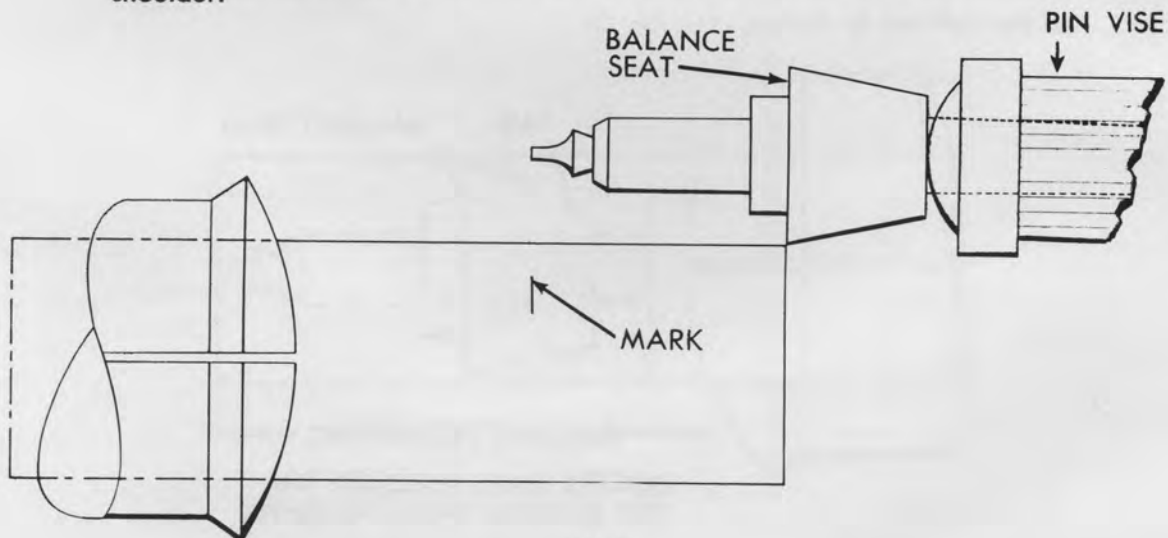

Fig. 4



Training Unit Number 3a

Gradually reduce the balance shoulder by straightening out the taper until the balance wheel fits. (See Fig. 7) The fit should be very close. Too tight a fit will stretch the balance wheel hole and may distort the balance wheel while riveting. Too loose a fit will put the balance wheel out of round when riveted.

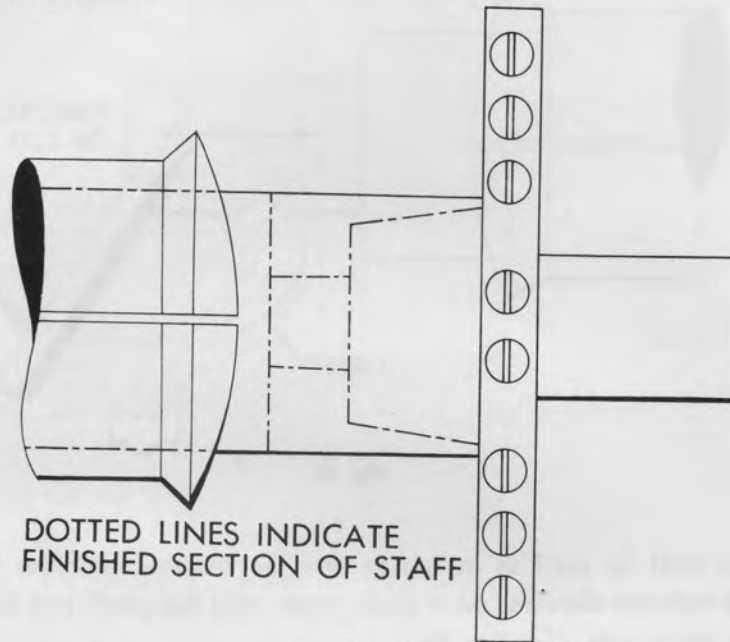

Fig. 7

Turn the hub of the staff, two hundredths of a millimeter larger in diameter than the hub of the sample. (See Fig. 8) This operation may also be done after upper part of the staff has been completed.

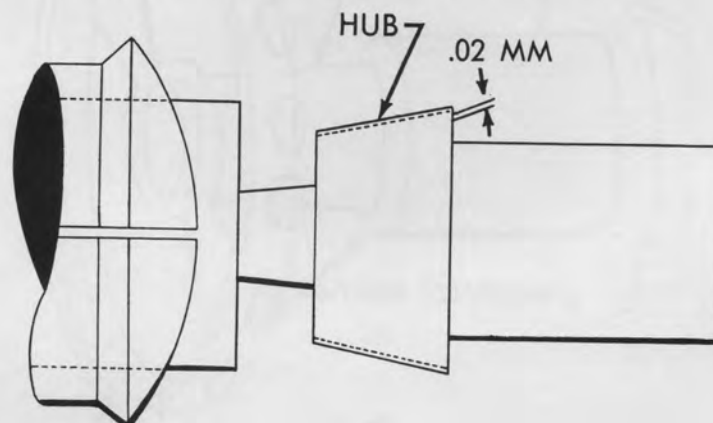

Fig. 8



Training Unit Number 3a

When you start the turning use the point of the graver to true the steel blank, then use the full cutting edge of the graver moving it along the work to avoid ridges. (See Fig. 5)

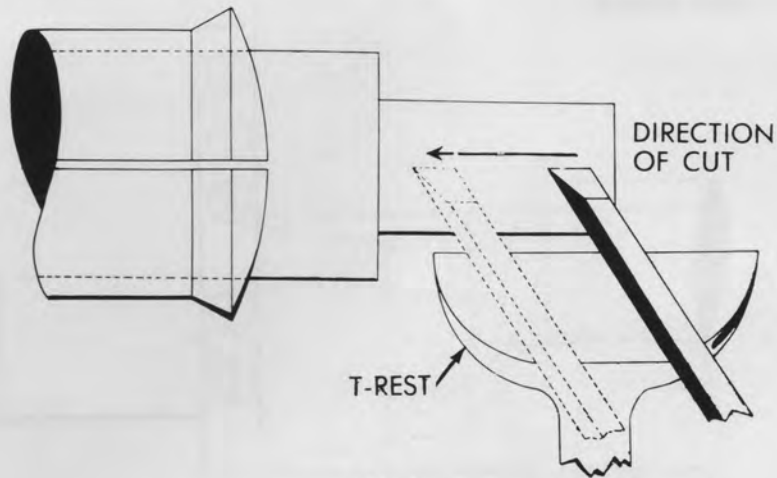

Fig. 5

Care must be used so as not to turn the balance shoulder too small. Turn the balance shoulder on a slight taper until the small end fits into the balance wheel hole. (See Fig. 6)

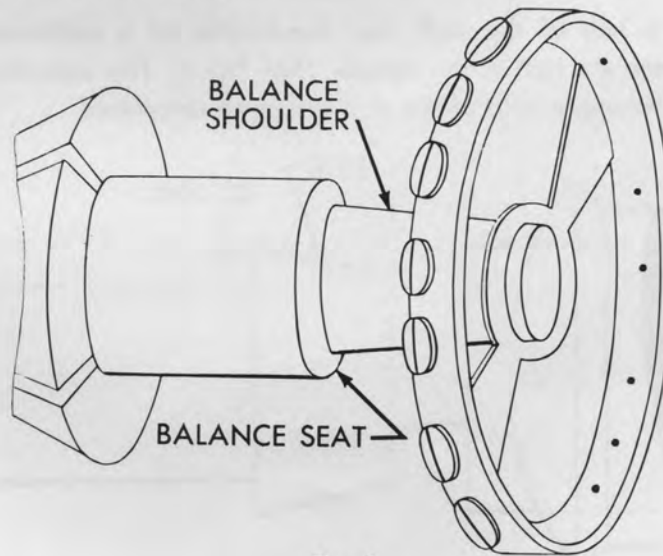

Fig. 6



Training Unit Number 3a

Gradually reduce the balance shoulder by straightening out the taper until the balance wheel fits. (See Fig. 7) The fit should be very close. Too tight a fit will stretch the balance wheel hole and may distort the balance wheel while riveting. Too loose a fit will put the balance wheel out of round when riveted.

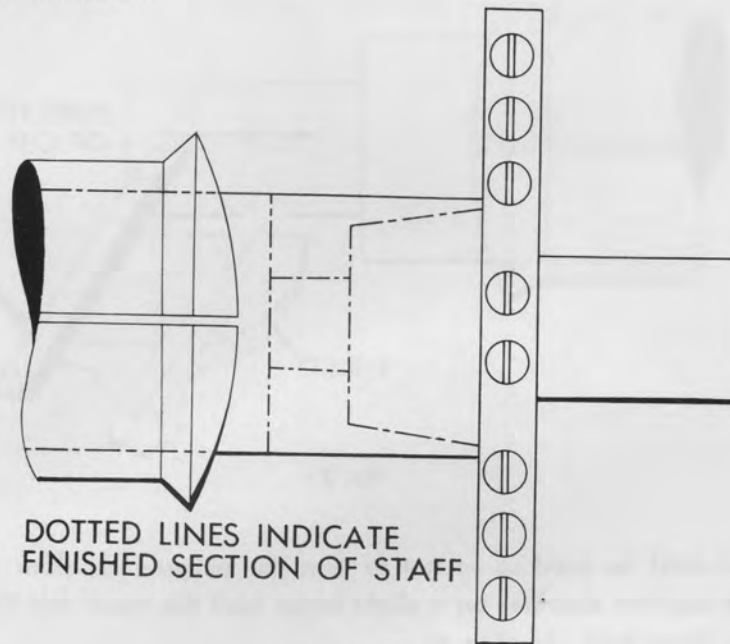

Fig. 7

Turn the hub of the staff, two hundredths of a millimeter larger in diameter than the hub of the sample. (See Fig. 8) This operation may also be done after upper part of the staff has been completed.

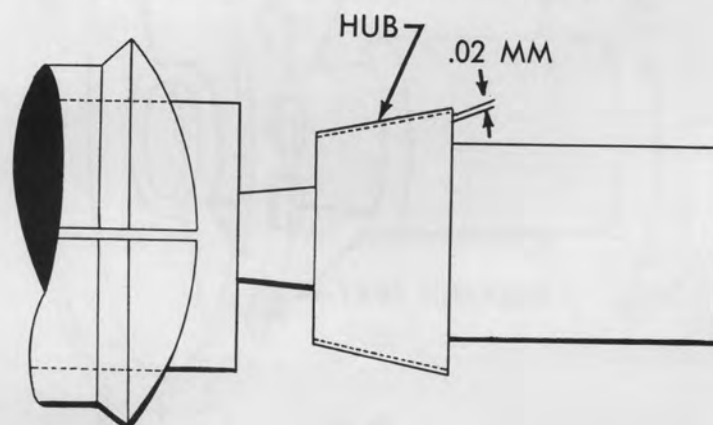

Fig. 8



Training Unit Number 3a

Use a sharp pointed graver to establish the undercutting for the riveting operation by presenting the graver to the stock as shown in Fig. 11.

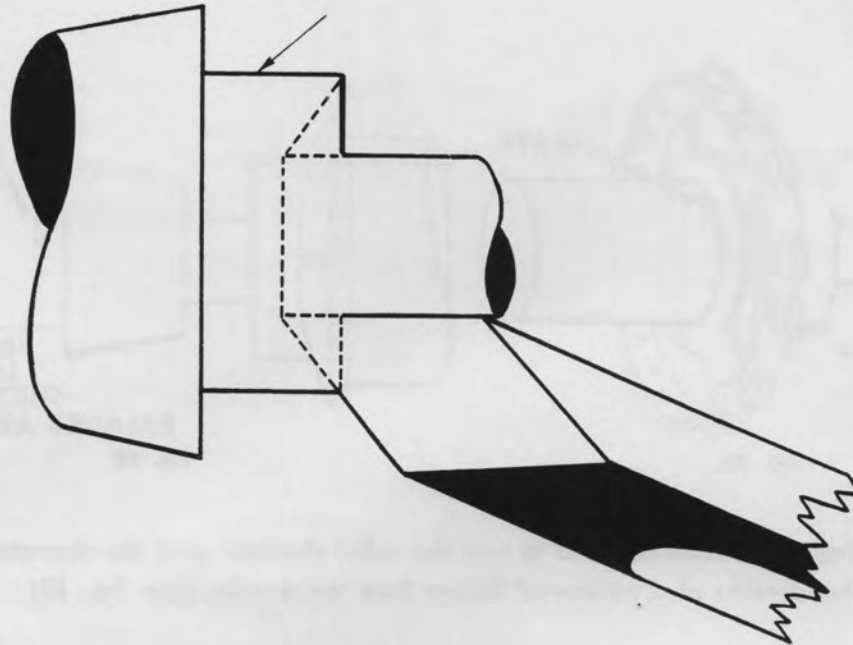

Fig. 11

Place the sample staff parallel with the blank, so that the length of the collet shoulder can be marked on the blank with a graver. (See Fig. 12)

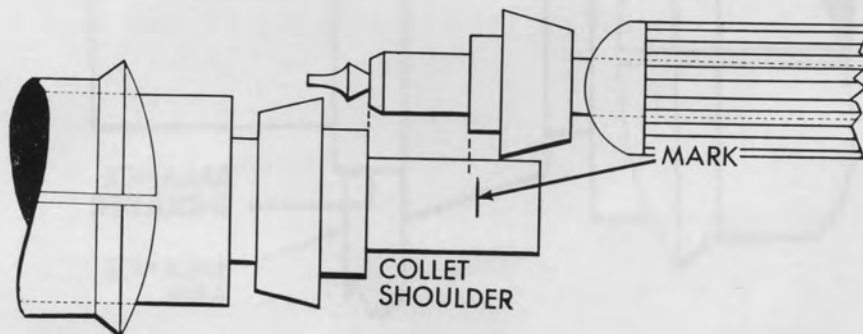

Fig. 12



Training Unit Number 3a

Put the balance wheel in position on the balance shoulder. Make a mark with the graver approximately one tenth of a millimeter above the balance arms. This determines the length of the balance shoulder. (See Fig. 9A and 9B)

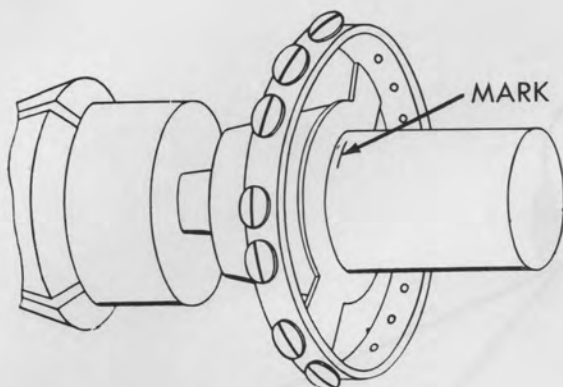

Fig. 9A

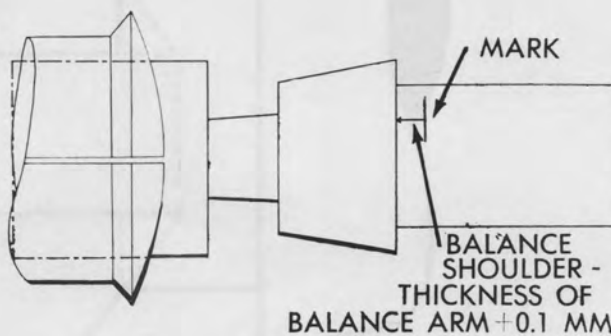

Fig. 9B

From that mark proceed to turn the collet shoulder until the diameter is two hundredths of a millimeter thicker than the sample. (See Fig. 10)

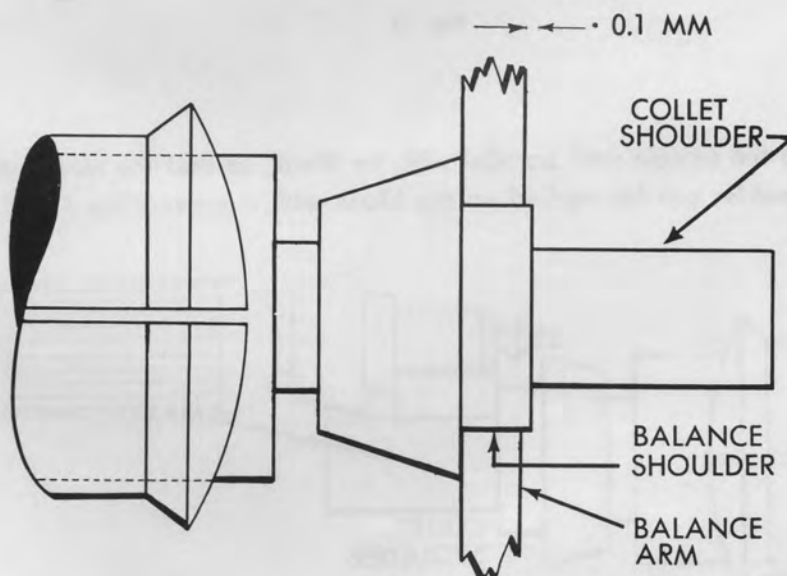

Fig. 10



Training Unit Number 3a

With a sharp pointed graver turn a back taper on the cone as shown in Fig. 16. This operation requires considerable care and practice, so as not to break off the fine point of the graver.

Turn a bevel on the upper end of the collet shoulder as shown in Fig. 17.

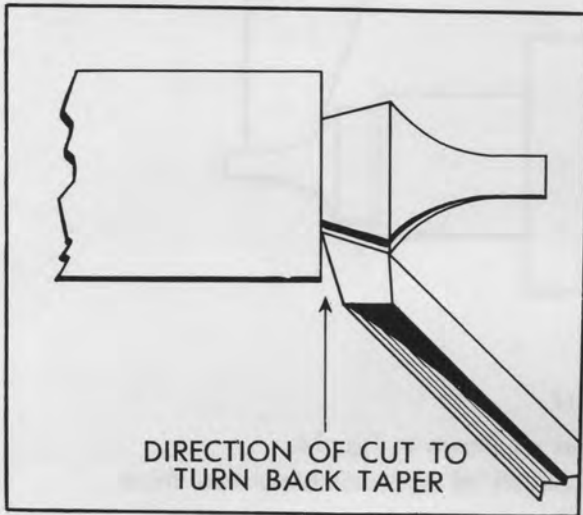

Fig. 16

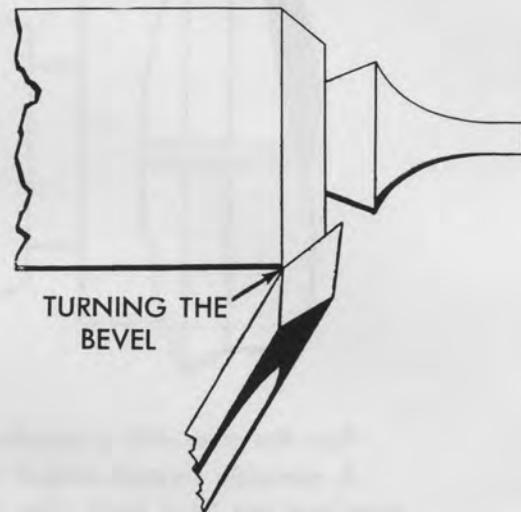

Fig. 17

Use an iron metal slip (See Fig. 18) charged with oilstone powder and oil, grind the hub and collet shoulder (See Fig. 19) in order to remove all traces of turning marks and to get the correct diameter. Clean off with pith wood to remove all traces of oilstone. Absolute cleanliness is essential before starting the polishing.

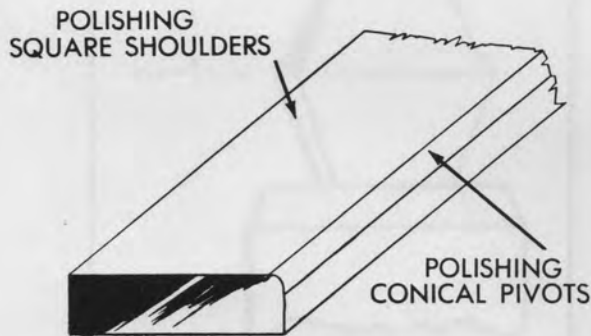

Fig. 18

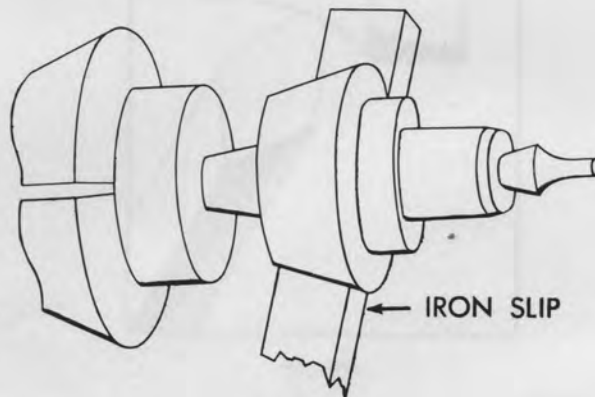

Fig. 19



Training Unit Number 3a

From that mark, turn the upper cone and pivot. (See Fig. 13) Try the jewel on the pivot frequently, using great care so as not to break the pivot or jewel, until the pivot starts to fit into the jewel. This will leave enough metal for grinding and polishing.

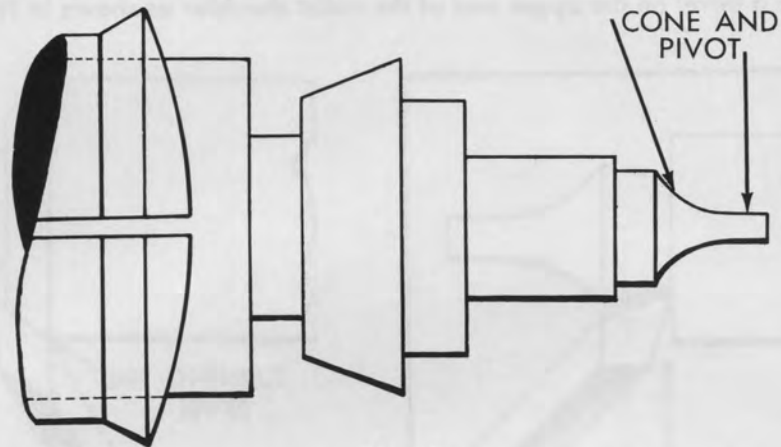

Fig. 13

Turn the cone with a rounded graver as shown in Fig. 14.

A correctly formed conical pivot consists of approximately two thirds cone and one third pivot. (See Fig. 15)

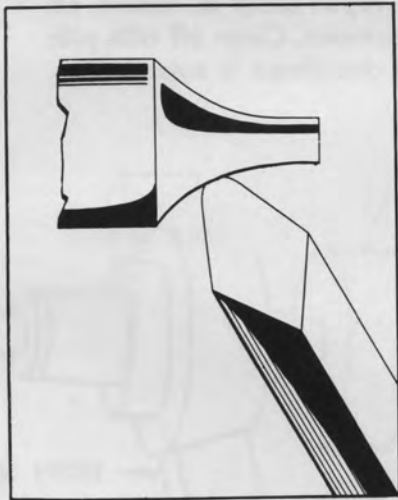

Fig. 14

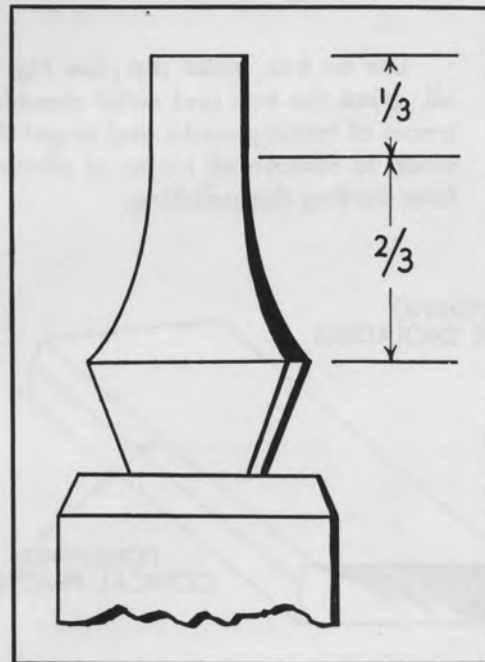

Fig. 15



Training Unit Number 3a

Use a sharp pointed graver to establish the undercutting for the riveting operation by presenting the graver to the stock as shown in Fig. 11.

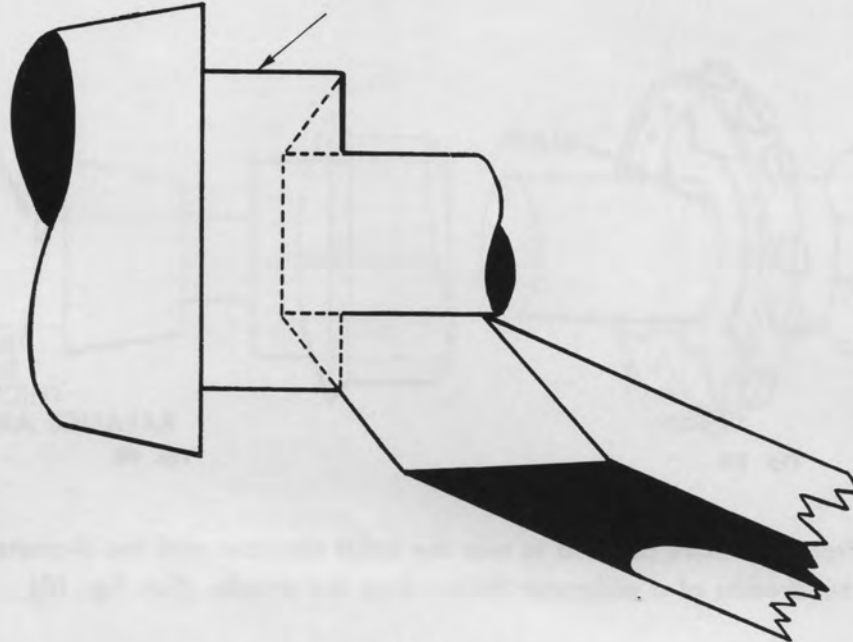

Fig. 11

Place the sample staff parallel with the blank, so that the length of the collet shoulder can be marked on the blank with a graver. (See Fig. 12)

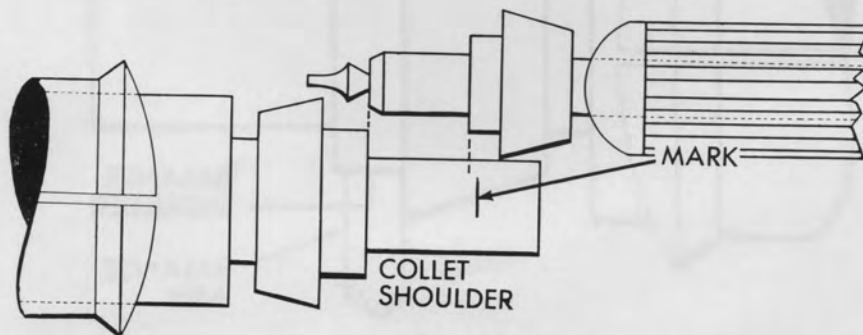

Fig. 12



Training Unit Number 3a

Put the balance wheel in position on the balance shoulder. Make a mark with the graver approximately one tenth of a millimeter above the balance arms. This determines the length of the balance shoulder. (See Fig. 9A and 9B)

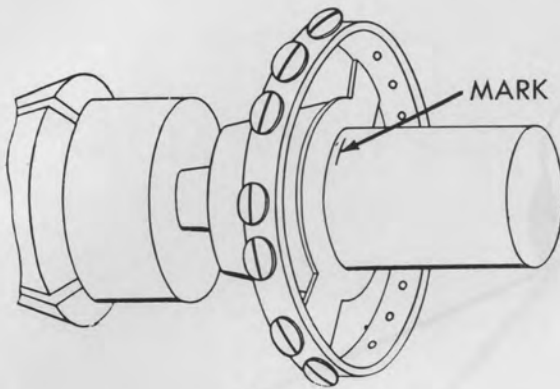

Fig. 9A

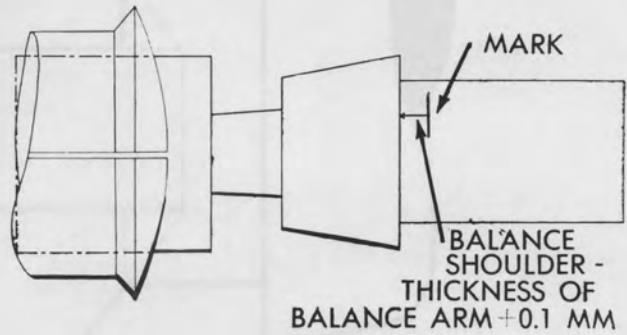

Fig. 9B

From that mark proceed to turn the collet shoulder until the diameter is two hundredths of a millimeter thicker than the sample. (See Fig. 10)

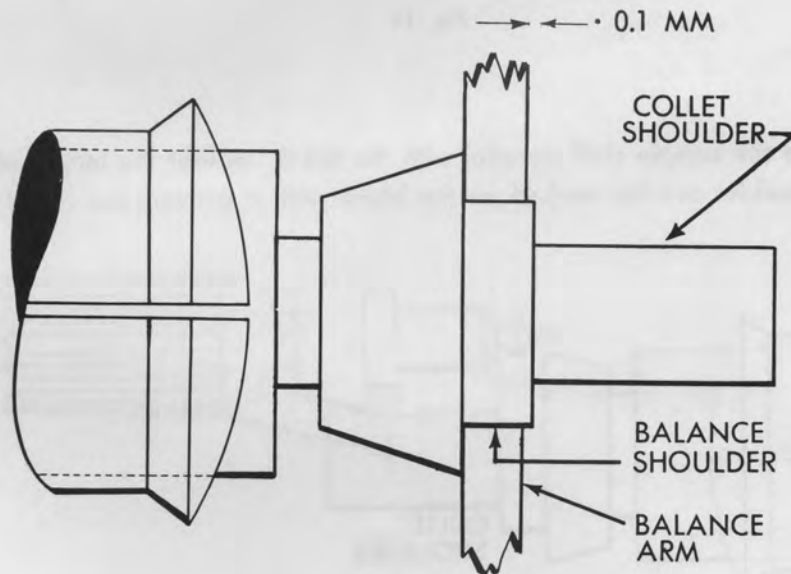

Fig. 10



Training Unit Number 3a

Gradually reduce the balance shoulder by straightening out the taper until the balance wheel fits. (See Fig. 7) The fit should be very close. Too tight a fit will stretch the balance wheel hole and may distort the balance wheel while riveting. Too loose a fit will put the balance wheel out of round when riveted.

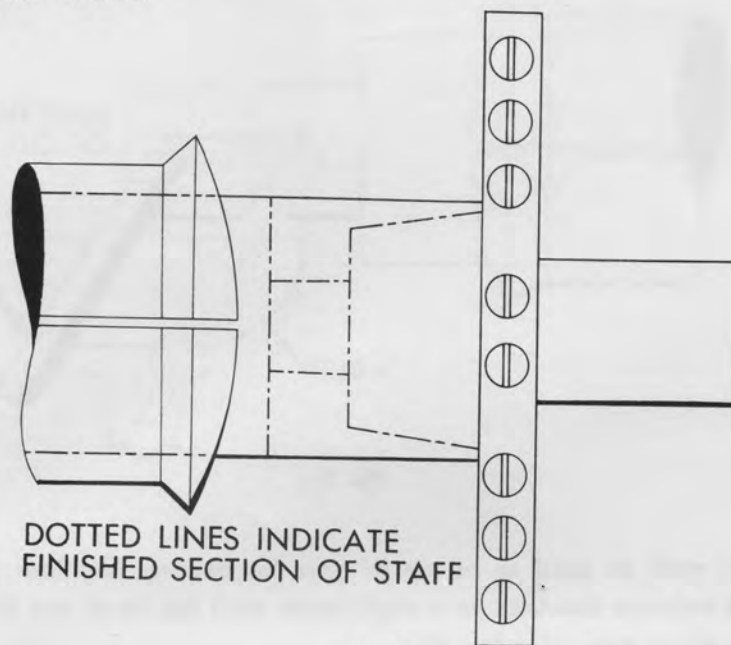

Fig. 7

Turn the hub of the staff, two hundredths of a millimeter larger in diameter than the hub of the sample. (See Fig. 8) This operation may also be done after upper part of the staff has been completed.

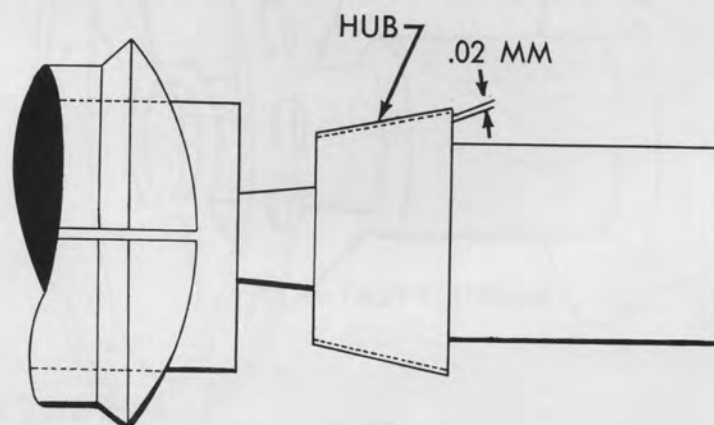

Fig. 8



Training Unit Number 3a

When you start the turning use the point of the graver to true the steel blank, then use the full cutting edge of the graver moving it along the work to avoid ridges. (See Fig. 5)

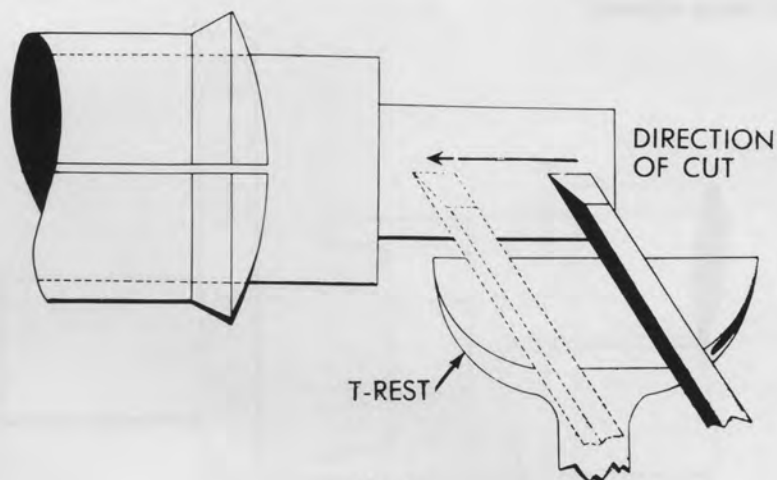

Fig. 5

Care must be used so as not to turn the balance shoulder too small. Turn the balance shoulder on a slight taper until the small end fits into the balance wheel hole. (See Fig. 6)

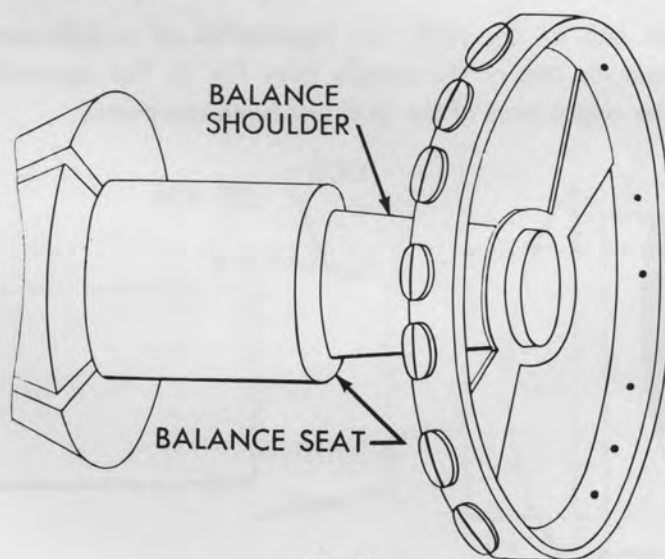

Fig. 6



Training Unit Number 3a

Tighten the chuck just enough to prevent the staff from falling out while the lathe is rotating. With the thumb nail, true the staff by applying a little upward pressure on the underside of the blank while the lathe is in motion. (See Fig. 3) Tighten chuck and with a loupe examine the blank for trueness. This will insure that when the graver is presented to the blank, that very little turning will be required to true it.

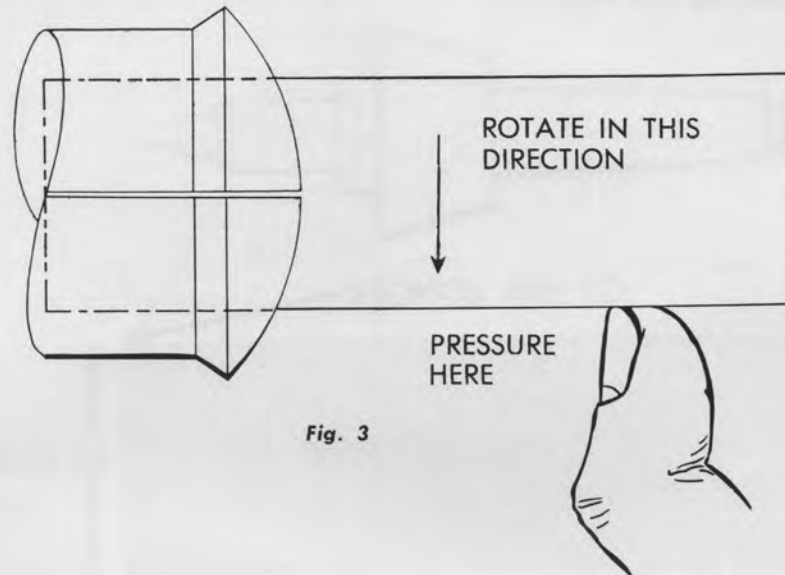

Fig. 3

Clamp the roller shoulder of the sample staff in a pin vise. Place the sample staff parallel with the blank, so that the balance seat can be marked with a graver. (See Fig. 4) From this mark proceed turning the balance shoulder.

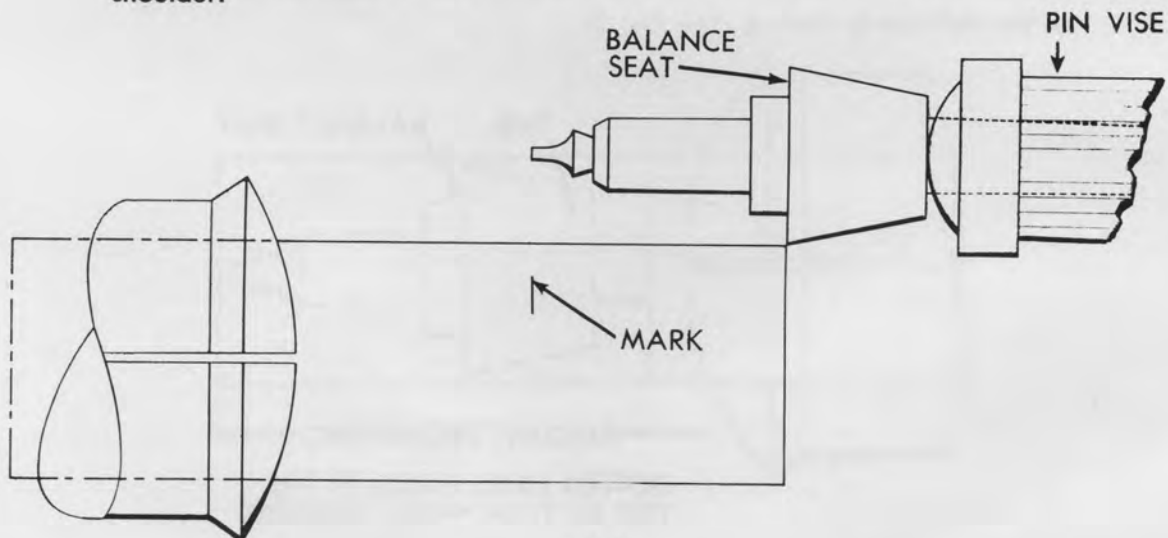

Fig. 4



Training Unit Number 3a

Select a piece of steel wire, with a diameter slightly larger than the largest diameter of the sample staff. In this case, stock of three millimeters thickness will be used. Make a blank one tenth of a millimeter longer than the sample. (See Fig. 1) Harden and temper this blank to a full blue color. (See hardening and tempering)

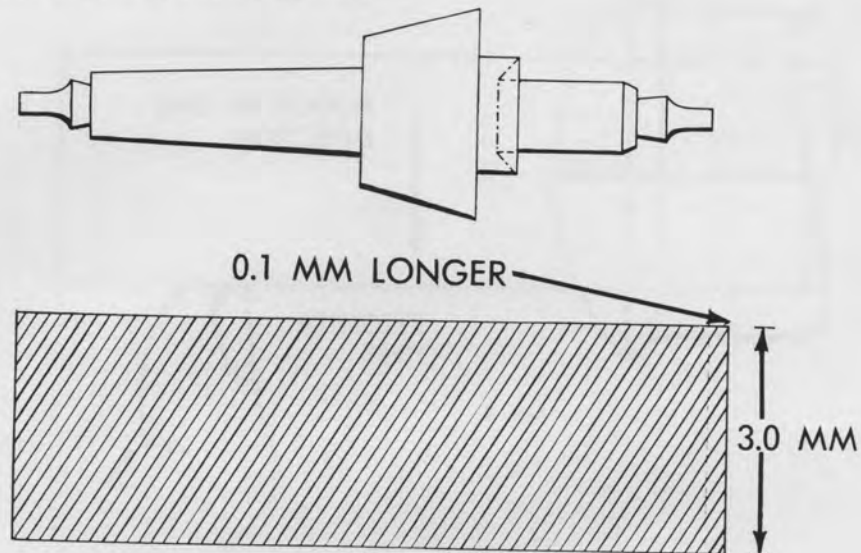

Fig. 1

Select a number 30 chuck which will fit the blank correctly. Chuck the blank in the lathe to extend out from the chuck far enough so that the hub of the staff can be turned. (See Fig. 2)

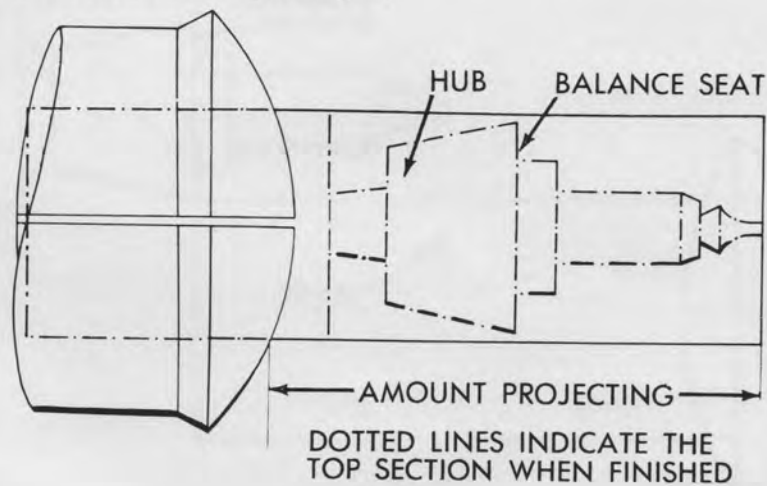

Fig. 2

